

DUAL BAND CURRENT PROBE FOR SMART ENERGY METERING APPLICATIONS

Marinov Angel, Technical University of Varna, a.marinov@tu-varna.bg

Abstract: This paper presents a specialized current probe for implementation into smart energy metering devices. The probe allows accurate and simultaneous measurement of currents with small and high magnitude, while eliminating the need of high gain amplifiers and high resolution ADCs. The probe's higher band is obtained by introducing a switched load. The switched load can be developed either by a fully controlled electronic switch – MOSFET or by a simple rectification diode. Analysis, computer modeling and verifications through simulations are presented for the suggested circuit.

Keywords: smart energy metering, current measurement, current probe

ДВУРАЗРЯДЕН ТОКОВ ТРАНСФОРМАТОР ЗА ИНТЕЛИГЕНТНИ ИЗМЕРВАТЕЛНИ СИСТЕМИ

Ангел Маринов, Технически Университет Варна, a.marinov@tu-varna.bg

Абстракт: Настоящата статия представя специализиран токов трансформатор с приложение свързано с интелигентните измервателни системи. Токовият трансформатор позволява едновременно измерване на малки и големи токове, като се елиминира нуждата от усилватели с голям коефициент на усилване или на високо разрядни аналогово цифрови преобразуватели. Двуразредеността на представеният токовият трансформатор се постига чрез превключване на товара. Превключването може да бъде реализирано както чрез напълно управляем електронен ключ – MOSFET, така и чрез обикновен изправителен диод. За предложената конфигурация на токовият трансформатор са представени анализ, компютърен модел и симулация чрез чиито резултати е верифициран принципа на действие.

Ключови думи: интелигентни измервателни системи, измерване на ток, токов трансформатор

Introduction

Smart metering is a modern concept that involves independent intelligent sensory units that utilize advances in technology in order to measure various parameters in both industrial and household applications. A fast developing concept that involves smart metering is electric energy metering. In smart digital electric energy metering current and voltage of a specific consumer are measured as their product over time gives the energy consumed by the observed device. [1]

Smart energy meters are usually used in electrical grid applications. Their main advantage over conventional electrical energy meters is that they allow precise measurement, load prediction, regulation, etc. Smart energy metering is set as a priority in the future development of the European distribution systems [2]. This calls for the development of precise, yet cost effective smart meters that can be integrated into house-holds without higher additional costs for users or distribution companies [3]. That justifies the development of new and improved current and voltage sensors that can be part of those smart metering devices [4].

For current measurement an important feature is the possibility to register both small and high magnitude currents, since devices connected to the electrical grid tend to have various working regimes and thus a various current consumption. In this way it is required for the current probe to have an accurate current measurement over a wide value band [5], [6]. Different structures exist that allow increased measurement range [7],[8].

The current paper presents a concept for a specialized current probe that has high current magnitude band and can operate accurately and simultaneous for both currents with high and low value. The suggested structure involves a switched load current transformer. Analysis, computer modeling and simulation results are presented.

Suggested topologies

The structural diagram of the presented probes are shown respectively on figures 1 and 2. For both structures the probe includes a conventional current transformer with a single secondary winding, where the higher band is achieved through a switched load. The probe is burdened with two resistors connected in series, where:

A. For the circuit from figure 1

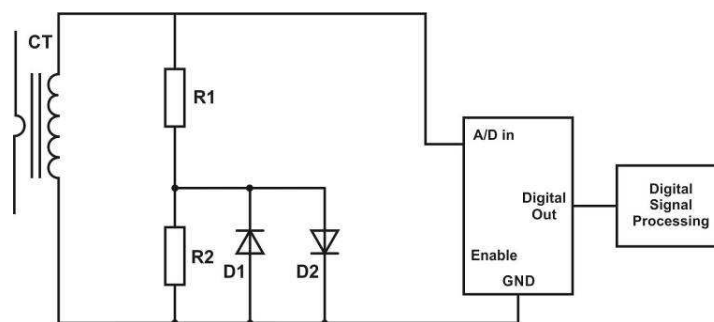

Fig. 1 Structural diagram of the suggested current probe using rectification diodes

An AC electronic switch made of two rectification diodes D1 and D2, connected in anti-parallel shunts one of the load resistors (R2) and thus changes the output characteristics of the probe. Diodes are switched based on the magnitude of the current. They will be switched, depending on the half-wave of the measured current, when the voltage on the load - in correspondence to the magnitude of the current - exceeds the forward voltage on the diode. Based on the state of the diodes - either on or off - two separate regimes can be distinguished: a high current one where

the probe is loaded only with R1 and low current one where the probe is burdened with the serial connected R1 and R2. Thus the probe can be defined as dual band. At the given circuit the voltage on the current transformer is measured by single ADC. For this circuit care has to be taken to correctly decipher the current based on the regime – this has to be handled by a specialized digital signal processing algorithm. The voltage drop of the diodes has to also be subtracted from the final result.

B. For the circuit from figure 2

A similar principle of operation is applied, with the difference that the AC electronic switch is made of two low resistance MOSFETs - S1 and S2. In the given diagram - figure 2 - the polarity switching of the transistors is determined by a set of comparators while the band switching is determined by the dedicated band generator that selects the appropriate regime, where the switches are controlled:

- based on the polarity of the current - S1 is switched for the negative half-wave and S2 for the positive half-wave, and
- based on the required regime - low current measurement or high current measurement.

The presented circuit uses a single ADC to determine the current. Here the regime is set separately by the controller so if the resistance of the MOSFETs is low enough no special digital signal processing is required.

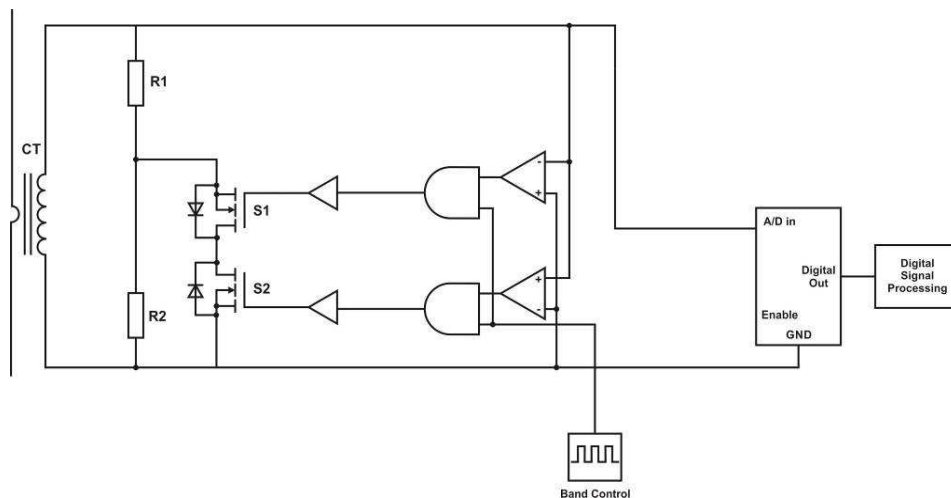

Fig. 2 Structural diagram of the suggested current probe using MOSFET switches

Computer modeling

The suggested circuit topologies as presented at figures 1 and 2 were modeled taking in account:

- Current transformer with transfer ratio 1:100 built using a nanocrystalline toroidal core. The model takes into account magnetic core saturation.

- The conduction and switching parameters of the diodes and the transistors.
- The required control logics.
- ADC modeled through a quantization block. A 10bit ADC is used.

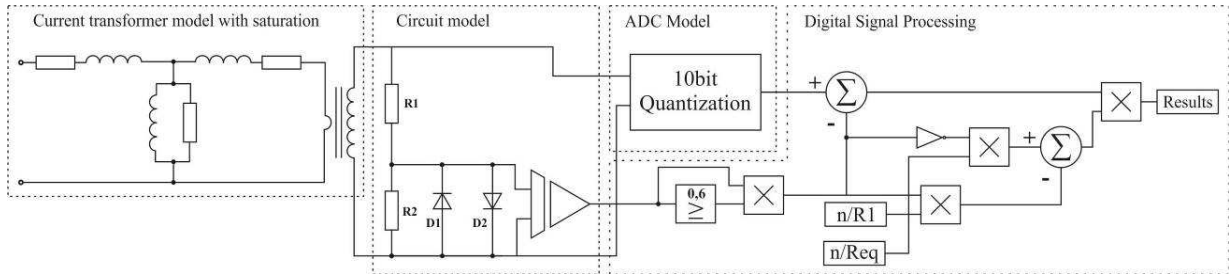

Fig. 3 Model diagram of the suggested current probe using rectification diodes

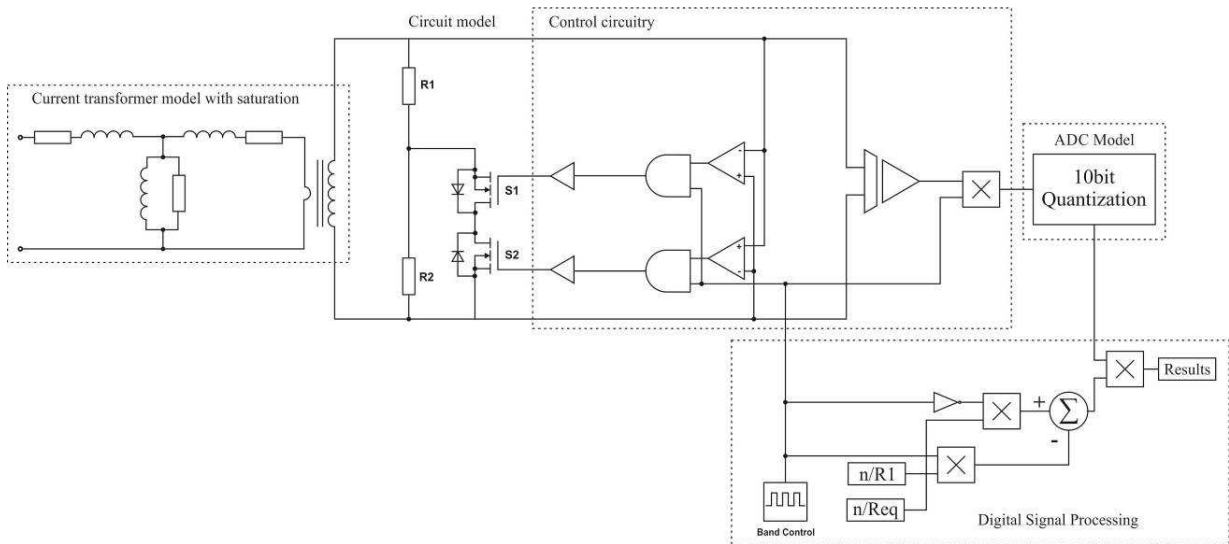

Fig. 4 Model diagram of the suggested current probe using rectification diodes

The circuits are modeled using dedicated computer software. For the simulations a sinusoidal current with grid frequency is analyzed. To test, two sets of currents are used: one with maximum value of 0,2A – low current; and one with maximum value of 20A – high current. Both selected currents are in the frames of what could be expected as a consumption from a domestic electrical application. The models of both circuits are presented at figures 3 and 4. The difference in the models is in the required control or digital signal processing, as specified in the previous section. For the structure from figure 3 a circuit for diode voltage drop omission is used, and for the structure from figure 4 a dedicated control block is used. Output results are respectively scaled based on the current band, either by multiplying by the transformer coefficient (100) and dividing either by the equivalent sum of the resistors R_1 and R_2 (for a low current band – diodes or MOSFET off) or by R_1 (for low current band – diodes or MOSFET on).

Load resistors for the simulations were calculated with values: $R_1 = 5\Omega$ and $R_2 = 10\Omega$, respectively their equivalent series resistance $R_{eq} = R_1 + R_2 = 15\Omega$

Verification through modeling and simulation

Using the models in a dedicated computer software – the trial version of PSIM – several set of results that can verify and quantify the operation of presented current probe were obtained. Those results are respectively presented at figures 5, 6 and 7.

Figure 5 presents a single band transformer, where the two extreme regimes are presented. The first graph (red) presents a low current over a low valued resistor – $I_{low} = 0.2A$ over a 5Ω resistor – resulting in a very low voltage drop therefore large quantization level by the ADC and lower accuracy. The second graph (green) shows a high current over a larger resistor – $I_{high} = 20A$ over a 20Ω resistor – resulting in transformer saturation. The two graphs are used as comparison points for the suggested circuit topologies.

Figure 6 shows results using the suggested diode switch dual band current probe. Here the first graph (red) shows a low current ($I_{low} = 0.2A$). This current does not create a voltage drop high enough to turn on the diodes. Therefore the current is conducting through the higher equivalent resistance $R_{eq} = 15\Omega$, thus creating a higher voltage drop that can be decoded with higher accuracy by the ADC. The second graph (green) shows a high current $I_{high} = 20A$ that creates a voltage drop high enough to turn on the diodes. This allows the transformer to be loaded with the smaller resistance of $R_1 = 5\Omega$, which prevents transformer saturation.

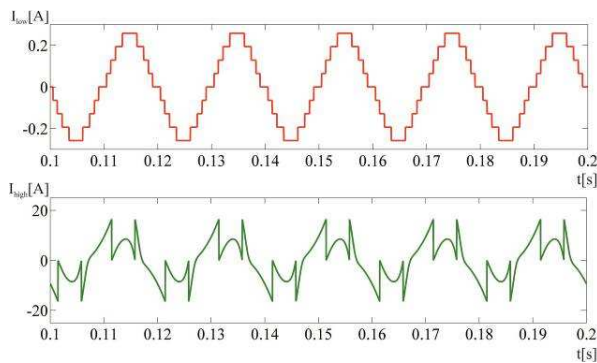

Fig. 5 Single band transformer

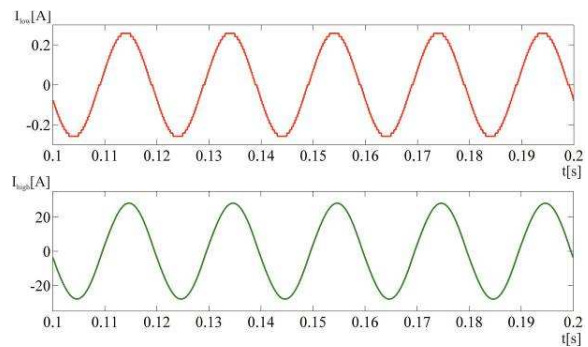

Fig. 6 Dual band transformer – diode switch

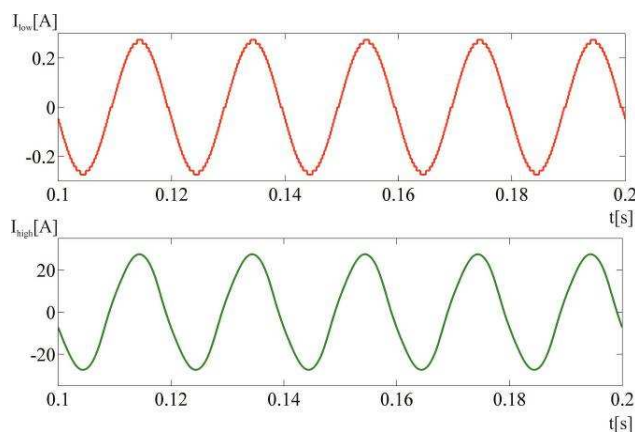

Fig. 7 Dual band transformer – MOSFET switch

Figure 7 shows results similar to those of figure 6, only here the switches are switched in the desired moment rather than when a certain current is reached. It can be observed for the first graph that a lower quantization level can be obtained in comparison with the first graph from figure 6.

The suggested figures give a verification for the suggested dual band current transformers. In the example from figure 5 where a single band is used it can be seen that when having a low resistance that can allow measurement of higher currents leads to high error in the lower current region, while having a higher resistance that can allow measurement of lower currents leads to transformer saturation. Those disadvantages are omitted in both the suggested circuits, where swapping between high and low loading resistance can be achieved.

Conclusions

Two types of topologies for dual band transformer for precise current measurement are suggested. Both circuits utilize load resistance switching. The circuits and their required digital signal processing are modeled and verified through simulation. Result show that functionality of the concept and motivate further studies through experimental and practical verification.

References

- [1] S. Sreenadh, R. Depuru, Smart meters for power grid: Challenges, issues, advantages and status, renewable and sustainable energy reviews, Vol. 15, p - p 2736–2742
- [2] Benchmarking smart metering deployment in the EU-27 with a focus on electricity, Report from the EU Commission, Brussels, 17.6.2014
- [3] Country fiches for electricity smart metering, Report from the EU Commission, Brussels, 17.6.2014
- [4] Cost-benefit analyses & state of play of smart metering deployment in the EU-27, Report from the EU Commission, Brussels, 17.6.2014

[5] D. Muñoz, D. Pérez, Design and experimental verification of a smart sensor to measure the energy and power consumption in a one-phase AC line, Measurement, Elsevier, vol. 42, 412–419

[6] D. Slomovitz, A Santos, A self-Calibrating instrument current transformer, Measurement, Elsevier, vol. 45, 2213-2217

[7] J. Kwiczala, A current transfer method and its application of calibrating a current comparator, IEE Transaction on Instrumentation and Measurement, Volume 38, Issue 5, p-p 979 - 983

[8] H. Brooks, The two stage current transformer, Transactions of the American institute of electrical engineering, volume XLI, p-p 382-393