

DESIGN OF A HYBRID SOLAR SYSTEM

Assoc. Prof. Todor Kostadinov, PhD
Ivelin Bakalov
Burgas Free University

Abstract: *The increasing demand on independent energy sources moves the scale of solar systems from large industrial solar farms providing to medium size farms suitable for businesses and small household-based systems. In contrast to the large solar fields providing hundreds of megawatts, the medium and small ones vary from several to several hundred kilowatts and do not have to meet industrial requirements. The lowered price of solar equipment allows designing a solar system that meets the custom needs of the users. To design such system a knowledge of the specifics of the solar systems is of the highest importance. This paper aims to present a design approach to build custom solar system, provide seamless operation 24/7.*

Keywords: *Hybrid solar system, design*

1. INTRODUCTION

Energy production is of critical importance for all aspects of contemporary life. With the energy prices constantly rising and the increase environmental requirements in electricity production [5, 6], interest has intensified in technological solutions for renewable energy sources, energy storages. There are three main types of renewable sources – wind, water solar energy. As the first two are geographically specific and do not apply in general terms for every region [2, 3], the solar energy is an energy factor available globally. It is also highly predictable in terms of duration and intensity. The process of solar energy utilization [1] involves specific equipment for transformation of energy type, controlling, conversion and storage. The generated energy can be either utilized or returned to the grid. Due to the periodical nature of the energy provided by the sun, such kind of systems lacks to supply energy during the night. In that case if present, the power storage is used instead. However, certain amount of energy can be drawn according to the storage capacity. For this system to operate seamlessly an alternative source of grid power is required in case of storage energy depletion and lack of sun radiation. In order to adjust the functionality of a renewable energy system to a certain amount of load, it is necessary to balance the three energy components that this system operates on – energy from the renewable source, energy from the power storage and energy drawn from the grid. It becomes obvious that a tradeoff between peak power, amount of stored energy and energy [4] from the grid must be made. The scope of this article is to present a design approach for a hybrid solar system including scaling the system performance according to the power demand and the process of selection of an appropriate equipment.

2. HYBRID SOLAR SYSTEM STRUCTURE AND DESIGN CONSIDERATIONS

As mentioned in the previous paragraph, for a renewable energy system to be optimal, a redundancy of the power output must be provided. To meet this requirement, a modern system must include several sources of power including the grid where the name „hybrid” comes from.



Due to the availability of the solar radiation, the solar type of renewable energy systems will be addressed in this article.

The process of power generation starts with transformation of solar energy to electricity, control the power input to a direct load, storage or an electrical energy conversion, utilization and direction on a local or a remote load, along with control over the amount of output energy provided from the system or consumed by the local load.

The overall diagram of a hybrid solar system is presented in fig. 1 where:

PV array – an array of series of DC semiconductor solar transformers in a rows, each row of the connected in parallel called solar panel. There are three main types of solar panels:

- monocrystalline Solar Panels. The core of their cells consists of a sheet of single, continuous silicon crystal. The crystal being a whole means that the electrons, which generate energy in the solar cell, have more space to move. Monocrystalline panels achieve an efficiency of up to 22%. They are capable of producing solar electricity to a greater extent even under cloudy conditions or during the lower solar altitudes in the winter months. Their lifespan is 25-30 years, with an efficiency of about 80% after 25 years.
- Polycrystalline Solar Panels – polycrystalline cells are made from coherent silicon crystals by melting multiple silicon fragments into each individual cell. Their efficiency is around 17%. They typically have a rectangular shape and are less costly to produce than monocrystalline panels. They are primarily used in large-scale solar parks.
- Thin-Film Panels - thin-film solar panels do not contain crystals, which makes them flexible. These panels perform better under low-light conditions and are suitable for cloudy or dim environments.

There are several types of semiconductors – amorphous silicon, low efficiency, around 7%, Cadmium telluride (CdTe)** – the most widely used, with efficiency up to 18%, CIGS (copper, indium, gallium, selenium)** – used in roof-integrated solar panels, with efficiency up to 16%.

Charge controller – provides monitoring of the energy flow between the solar panels and the batteries, regulating the amount of charge and the magnitude to prevent damage caused by overcharging or over-discharging. Essentially, it ensures that the batteries receive the optimal voltage and current for efficient charging and longevity. This module is a part of the Maximum Power Point Tracking controller – MPPT.

Rectifier – used to convert the electricity from AC to DC to accumulate power from the grid to the storage. Also part of the MPPT controller.

Inverter – the hybrid inverter is an intelligent device that enables excess solar DC energy to be stored in a battery system for later personal use and converted to AC for the purposes of local or remote load supply. These inverters can operate in various modes depending on application – battery backup mode, providing a limited level of emergency power supply in case of a power outage, but also in a mode without batteries, exporting excess solar energy directly to the grid or the load.

Battery – an array of electrochemical components used to store charge. They can be several types:

- Lead-Acid Battery - this is the oldest type of rechargeable battery, comprising lead and lead dioxide electrodes in a diluted sulfuric acid electrolyte. Though it has a low energy-to-weight ratio, it tolerates high discharge currents without damage.

- Lithium-Ion Battery (Li-ion) - lithium ions move between the electrodes during charge/discharge cycles. These batteries use intercalated lithium compounds for one of the electrodes. Due to their widespread use in electric vehicles, repurposed Li-ion batteries present an increasingly ecological and cost-effective solution for energy storage — particularly when their capacity remains above 75%.
- Electric Vehicles as Energy Storage Units – with the development of ****bidirectional charging****, electric vehicles integrated into a hybrid solar system can function as mobile batteries for storing surplus energy.

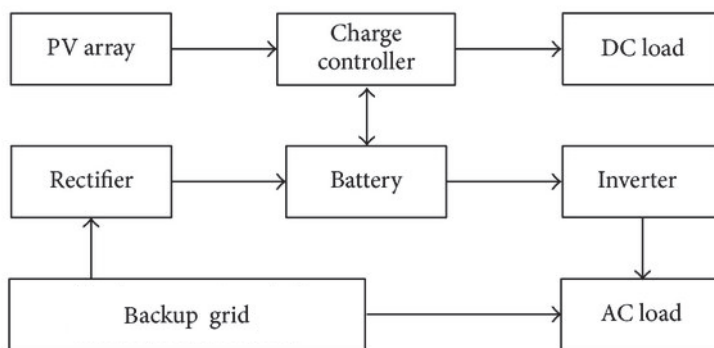

Figure 1. Structure of a generic hybrid system

The design starts with definition of the power output to the AC load in general. The amount of power required on the output specifies the output power of conversion circuit known as the inverter, where the output power – AC and DC in total is a product of the input power the power transformation factor and losses. The DC output specifies the nominal storage capacity denoted as Battery in fig. 1. The maximum amount of DC input power is limited by the inverter and specifies the number of solar transformers presented as PV array in fig.1. The inverter is the first component to be chosen as it specifies

- the maximum output power to the load/grid or drawn from the grid to power the load/accumulate energy in the storage,
- the capacity of the storage according to the peak output power of the inverter,
- the amount of input power provided by the photovoltaic panels,
- maximum and minimum amount of input energy required,
- maximum and minimum magnitude of the storage energy.

The design needs specific power requirements as described in the next paragraph.

3. AN EXAMPLE OF A HYBRID SOLAR SYSTEM

Considering the design sequence proposed in the previous paragraph, in order to build a hybrid solar system, it is necessary to define the power output – about 1600 Watts sufficient for small office usage. With a requirement of easy integration with the existing grid, support of variety of energy storage in type and capacity, charge control and bi-directional conversion. It must be suitable for outdoor install. The initial investment must be paid off by the production for a maximal period of three years.

A hybrid inverter suitable for the purpose is the IMI – 1600, presented in fig.2



Figure 2. An overview of IMI-1600 hybrid solar inverter

It is capable to provide up to 1600 watts of energy required for heating / cooling a small office with a personal computer operating 24/7. It supports wireless communication to a 802.11 network as well as a mobile 5G modem for communication purposes.

Further information concerning the design can be found in the specification sheet, posted in fig. 3.

As can be seen, the inverter covers the rectifier and charge controller functions with the embedded MPPT controller, Supports different types of solar panels with power from 250 – 400w, in parallel groups of several panels connected in series according to the required current and voltage to obtain 1600 watts – PV voltage from 33-50 volts and maximum current of 4x7.5 Amps. Voltage interval of the storage from 18 to 52 volts and maximum current of 20 Amps. The controller supports any storage type.

According to the design, after choosing the maximum output power, the storage capacity and type of the controller, it is required to choose the solar panels type. As shown in fig. 3 the controller supports 1600 watts on four PV inputs each with current limitation of 7.5 Amps at maximum. The requirements lead to the selection of a 200 watts solar panel with the following specifications:

Peak Power: 200W \pm 5%

Open Circuit Voltage (Voc): 44.4V

Short Circuit Current (IOC): 5.95A

Maximum Power Voltage (Vmp): 36.6 V

Maximum Power Current (Imp): 5.45A

Solar Energy Conversion Rate: 19%-22%

Operating Temperature: -20 ~ 60 °C/ -4 ~140 °F

All technical data at standard test condition

E=1000W/m² TC=25°C AM=1.5

Size: 2230 x 650 mm(87.8 x 25.6 in) / 650 x 515 mm(25.6 x 20.3 in)

Weight: 6.3 kg / 13.9 lb

This will provide nominal power of about 850 watts of input power. In order to provide additional power, the same manufacturer can provide 100 watts panels with the same current operating on 18.8 volts. Connecting a 100 and 200 watts panels in series results in a total amount of 1400 watts on 4 channels which is about 90% of the nominal power of the controller.

Международна научна конференция „Съвременни управленски практики XII“
РАЗВИТИЕТО И ОБУЧЕНИЕТО НА МЕНИДЖЪРИ И ПРЕДПРИЕМАЧИ
В ИНДУСТРИЯ 5.0

The grid connection is performed by a shuko plug, connected to the office power grid. A smart fuse is used to disconnect the power grid from the office installation.

To preserve the accumulated energy, a single battery pack from Renault zoe, consisting of 8 lithium cells – 33.6 volts / 4.5 W/h in total is considered. The proposed battery pack, presented in fig. 4 is air cooled LGX E78 / LG Chem NCM (nickel – cobalt – mangan) type, obtained by a defected battery pack of a Renault EV.

The design is intended to serve as a reference point in the build of the described system in practice which will be a subject of future work. This will provide practical results of the system parameters and behavior.

High-concerned Chemical	None	is_customized	Yes
Output Current	@120VAC 5A; @230VAC 2.6A	Model Number	IMI1600
Output Power	1600W	Size	365x230x40mm
Output Type	Quad	Weight	3.5KG
Brand Name	VESDAS	Output Frequency	50/60Hz(48~61Hz)
Is Smart Device	Yes	Origin	Mainland China
Color	Black	Recommend PV	250~400W*4
Operation voltage	20~50V(MPPT:22V~48V)	Recommmend PV Voc	33~50V
Star/Max input voltage	18V/52V	Max input current	7.5A*4
Max Output Power	1600W	Rated output current	@120VAC 5A; @230VAC 2.6A
Rated voltage	@120V(90~160VAC); @230V(190~270VAC)	Max units per branch	@120V: 2PCS; @230V:4PCS
Rfrequency	50/60Hz(48~61Hz)	Static MPPT	0.995
Power factor	>99%	Max output	0.95
Self consumption	<1W	THD	<5%
Ambient temperature	- 40°C to + 85°C	Operating temperature	- 40°C to + 65°C
Dimensions(L*W*H)	365*230*40mm	Weight	3.5KG
Waterproof Rating	IP65	Max current of AC bus cable	20A
Cooling	Self-cooling	Power transmission mode	Reverse transfer, load priority
Communication	WiFi(QR code scanning, automatic matching internet)	Design	High frequency transformer, Galvanically isolated

Figure 3. Specification of IMI-1600 inverter



Figure 4. Renault Zoe battery pack

CONCLUSION

A design approach of a hybrid solar system has been proposed in the present paper. The aim is to define an approach to implement a working system and define the parameters and expected output. The goal is to define the implementation process of a budget small scale solar system which will serve as a test rig to experiment with the capability of an EV to become a dynamic energy source for a hybrid solar system by implementing communication with the BMS (battery management system) controller, or the vehicle electronic management system.

References:

4. S. Moomin, M. Yousif, H. A. Khalid, S. A. A. Kazmi, and A. H. A. Thamer, „Evaluation of Techno-Economic Design and Implementation of Solar-Wind Hybrid Microgrid System for a Small Community,” *Heliyon* 10, no. 17 (2024)
- A. Vincent, „Design of a Reliable Hybrid (PV/Diesel) Power System With Energy Storage in Batteries for Remote Residential Home,” *Journal of Energy* 2016 (2016): 1–16
5. K. Yemeli, A. Clint, N. Wankouo, C. V. F. Fodoup, and T. Ghislain, „Optimisation and Comparative Analysis of Hybrid Renewable Energy Systems for Sustainable and Clean Energy Production in Rural Cameroon Considering the Loss of Power Supply Probability Concept,” *Energy Conversion and Management* 25 (2025)
6. Sadeghibakhtiar, N. Afshin, N. Shayan, P. Gloria, and A. Behbahaninia, „Size Optimization of a Stand-Alone Solar-Wind-Battery Hybrid System for Net Zero Energy Buildings: A Case Study,” *Energy and Buildings* 313 (2024)
7. Lis, A. Volodymyr, and O. Piotr, „Hybrid Photovoltaic and Energy Storage System in Order to Enhance Self-Consumption Energy – Poland Case Study,” *Journal of Energy Storage* 91 (2024)
8. Liu, C. Xi, C. Sunliang, and Y. Hongxing, „Overview on Hybrid Solar Photovoltaic-Electrical Energy Storage Technologies for Power Supply to Buildings,” *Energy Conversion and Management* 187 (2019)