

MODELLING OF A HYBRID PHOTOVOLTAIC SYSTEM

Assoc. prof. Todor Kostadinov PhD, Ivelin Bakalov
Burgas Free University

Abstract: *The rising environmental and economic demands along with the development of the solar panel technology, an increase in interest in electricity obtained from the sun is observed. Key points in the solar systems design are determining the levels of solar intensity and energy storage capacity. The present work presents a model of a photovoltaic system, enabling the configuration of parameters such as generated power and storage capacity of similar systems.*

Key words: *Photovoltaic systems, modeling of hybrid systems, determination of the capacity of photovoltaic systems.*

МОДЕЛИРАНЕ НА ХИБРИДНА ФОТОВОЛТАИЧНА СИСТЕМА

доц. д-р Тодор Костадинов, Ивелин Бакалов
Бургаски свободен университет

Резюме: *С нарастващите екологични и икономически изисквания, и развитието на технологията за изработка на соларни панели се наблюдава повишаване на интереса към електроенергията добивана от слънцето. Основни моменти при проектирането на подобни системи са определяне на нивата на слънчевата интензивност и нейното съхранение. Настоящата разработка представя модел на фотоволтаична система, даващ възможност за конфигуриране на параметри като генерирана мощност и капацитет на съхранение на подобни системи*

Ключови думи: *Фотоволтаични системи, моделиране на хибридни системи, определяне на капацитета на фотоволтаични системи.*

1. INTRODUCTION

The technology for solar energy utilization is presented back in the early 19th century. It was not fully developed due to the presence of many alternatives of energy sources back in the days. Although the sun is an infinite source of energy, the lack of technology and the reduced performance prevented the advance of solar technology. The global depletion of resources together with the increased power consumption for civil and industrial needs in present days, combined with high ecological standards led to increased need for clean energy [1, 2]. The moder technology provides plenty of automated systems for control acquisition and monitoring (SCADA) [3 - 5], aiding the performance of energy harvesting and utilization. The trend of solar panels aims improvement of the specific output power density in order to meet the power supply requirements [6] with the goal of high-power output in a wide range of irradiation and sun light angle of incidence [7]. The load balance approaches [8] provide further improvement of the performance drop caused by shadowing.

Considering the improvement mentioned above the solar technology is up to date source of power. However, there are certain specifics in the design and implementation such as the required power output, the specific amount of power provided to the grid and the instant demand of energy in 24 hours. In order to get maximum efficiency from the sun,

several parameters such as hourly sunlight intensity during the year, angle of incidence, dust particles concentration in the air must be known. This is caused by the fact that the energy is generated only during the light part of the day and to provide optimal output an energy storage [9] is required. In other words, a hybrid photovoltaic system comprised of solar panels and energy storage addresses this issue, but a problem of constant power output remains as it is dependent on the meteorological conditions [10, 11]. This means that a solar grid providing enormous peak power output in best conditions would not be suitable as the peak moment the generated power will certainly surpass the consumption but will not provide enough energy when dark. A tradeoff between peak power and storage capacity is present. Ideally the storage capacity would be equal to the maximum of the total generated power in best case scenario, however this will lead to expenses greater than the value of the produced energy.

To aid the design of an optimal system, an implementation of simulation model of a hybrid photovoltaic system is addressed in the present paper. The model allows to adjust the specific power output according to the irradiation input, number of solar panels, changing output performance and account energy conversion and storage. This will allow to simulate the productivity according to input data from sunlight and temperature measurements, level of dust and shading, aiding the cost reduction.

2. OVERVIEW OF A HYBRID SOLAR SYSTEM

A solar system is based on the photovoltaic (photoelectric) effect where a semiconductor solar element subjected to absorption of solar radiation emits electrons from the material, causing an electric potential of approximately 0.5 to 0.6 volts. The photoelectric elements arranged in rows and connected in series produce greater voltage. The parallel connection of multiple rows of elements produce higher current. However the generated voltage produces a direct current (DC) through the load. This makes it not suitable for any alternated current (AC) loads, but on the other side DC voltage can be stored directly by any electrochemical energy storages. In order to utilize the energy by any household appliance it must be converted. The main disadvantage of the solar systems is the limited amount of energy produced due to the lack of solar irradiation during the night. This problem is addressed by the hybrid photovoltaic (PV) systems, combining solar energy generation with other energy sources and storage solutions to provide a reliable and uninterruptable power supply. The hybrid systems are greatly used in applications where the power grid is unreliable or unavailable by integrating multiple power sources. In addition to the conventional solar systems the hybrid photovoltaic systems are comprised of a storage where the energy is conserved, a circuitry to maintain the power storage and a switching circuit providing alternative sources of power and energy conversion.

A block diagram of a hybrid system where the components are represented as labeled blocks, and their interconnections illustrating the energy flow is presented in fig. 1.

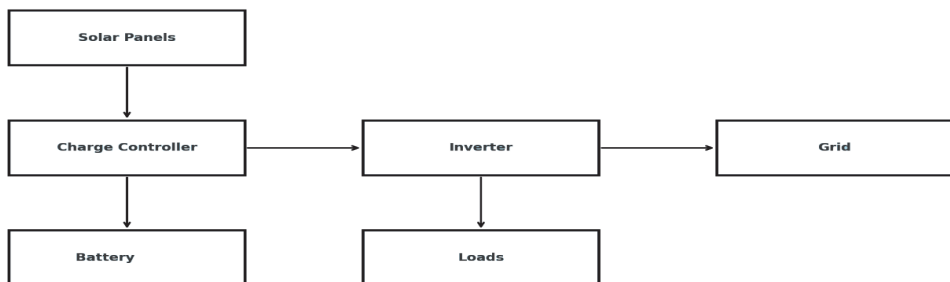

Figure 1. Generalized block diagram of a hybrid solar system

The solar radiation from the sun incident to the solar panels provide DC power to the Charge Controller. In order to specify a working voltage and current the photovoltaic voltage must be regulated and set in specific boundaries for the purposes of storage and conversion later on. For that matter a charge Controller is used on one side to keep the input to the regulator constant a step up or step down DC converter is used. It regulates power to the battery for storage and to the inverter for conversion and immediate use by an AC load. It converts DC to AC and supplies power to the Loads (appliances). It also manages input from auxiliary sources if present. Auxiliary Sources could be the Grid and Generator connect to the Inverter for backup power.

According to the block diagram in fig. 1 the main solar system components and their functionality are specified briefly as follows:

- Solar Panels – the fundamental part of a hybrid photovoltaic system. They can capture sunlight and convert it into direct current (DC) electricity. Photovoltaic cells within these panels rely on the photovoltaic effect, whereby light energy excites electrons to generate an electric current. Panels are typically arranged in arrays to meet specific energy demands, and their output depends on factors like irradiance, temperature, and panel efficiency.

- Charge Controller – the electricity generated by the solar panels flows into a charge controller, a critical component that regulates the voltage and current to prevent overcharging of the connected batteries. Modern charge controllers, such as Maximum Power Point Tracking (MPPT) systems, optimize the power harvested by maintaining the solar panels at their maximum power point. This ensures efficient energy transfer while protecting the battery from damage due to overcharging or excessive discharge.

- Battery Storage - a battery bank is incorporated into the hybrid PV system to store surplus electricity generated by the solar panels. This stored energy can be utilized during periods of low sunlight, such as at night or during overcast conditions. Lithium-ion and lead-acid batteries are common options, with lithium-ion offering higher efficiency, longer lifespans, and better energy density. The capacity of the battery bank is carefully sized based on the load requirements and desired autonomy.

- Inverter -the inverter is responsible for converting the DC electricity from the solar panels or battery storage into alternating current (AC) electricity, which is used by most household and industrial appliances. Hybrid inverters also manage the interplay between various power sources, including the solar panels, batteries, and grid, ensuring optimal energy flow. Some advanced inverters are bi-directional, allowing for battery charging from the grid if needed.

- Auxiliary Power Sources – if present they are a definitive feature of hybrid PV systems is their ability to integrate auxiliary power sources, such as the grid or diesel generators. These sources provide backup power when solar generation and battery storage are insufficient. The system intelligently switches between sources to maintain continuous power supply. Grid-tied systems can export excess electricity back to the grid, further enhancing energy efficiency and reducing costs.

- Monitoring and Control System – if present it represents a sophisticated monitoring and control system ensures smooth operation of the hybrid PV system. This system collects real-time data on energy generation, storage, and consumption, allowing users to monitor performance and make informed decisions. Advanced systems use algorithms to prioritize energy use, such as charging batteries during low-demand periods or using stored energy during peak hours to reduce reliance on the grid.

The block diagram of a hybrid PV system presented in fig. 1 operates in the following principle - solar panels: transform sun radiation into DC power fed to the charge controller. The controller regulates power flow to the battery storage and the inverter circuitry. The battery stores DC power for later use during solar panels shadowing or providing power during the night, it is connected to the charge controller and the inverter. The inverter converts the DC power provided from the solar panels or batteries into AC power to power the load. It also manages the interaction between the grid and potential auxiliary power sources. The load can be represented as appliances or systems consuming electricity, connected to the output of the inverter. Auxiliary Power Sources such as power grid or generator connections can be attached to the system connected to the inverter for backup.

In a typical configuration, solar panels supply energy directly to loads via the inverter during daylight hours. Any power exceeding the load consumption is stored in the batteries for later use. If solar energy and stored power are insufficient, the inverter draws either from the battery storage or the auxiliary sources to meet demand, ensuring a continuous power supply.

Conclusion

Hybrid photovoltaic systems provide a versatile solution for sustainable energy generation by seamlessly integrating solar energy, battery storage, and auxiliary power sources. Each component plays a crucial role in the system's efficiency and reliability, with advanced monitoring and control ensuring optimal operation. As the demand for renewable energy grows, hybrid PV systems represent a crucial step toward a resilient, clean energy future.

3. MODELLIN THE HYBRID PHOTOVOLTAIC SYSTEM

The implementation of a solar system is a complex task including several key components such as average amount of monthly sun radiation, consumed power to the load and power output from the solar panels. In a case of very large solar panels grid, the effect of the angle of incidence is also a part of the design due to the elliptical shape of the earth surface. To design an optimal system, the total amount of power consumption must not surpass the generated power. However, the average amount of power generated by the system can be predicted in contrast with the peak power consumption. Another key point is the power output during the night, as it strongly depends on the battery capacity. In order to design a cost effective system it is necessary to predict all of the variables and take into account the worst case scenario. This could lead to increased costs for battery storage as the lack of solar power must be balanced by the battery storage, meaning increased capacity and thus increased costs. An option to reduce the costs would be to perform a minimalistic design with the lowest possible cost and improve the performance on demand. This option is not applicable as it leads to power outages during system maintenance.

Modelling a solar system simulation model can account all the forementioned parameters and provide an accurate estimation of the system parameters. Simulink was chosen as a simulation environment as it based on predefined blocks with specific properties and behavior picked from the toolbox. The function blocks can also be created by the designer and generalized as a sub model for later use. The function blocks properties can also be provided as a programming code which improves the implementation capabilities of the simulation. A simulink model of a hybrid solar system is depicted in fig. 2.

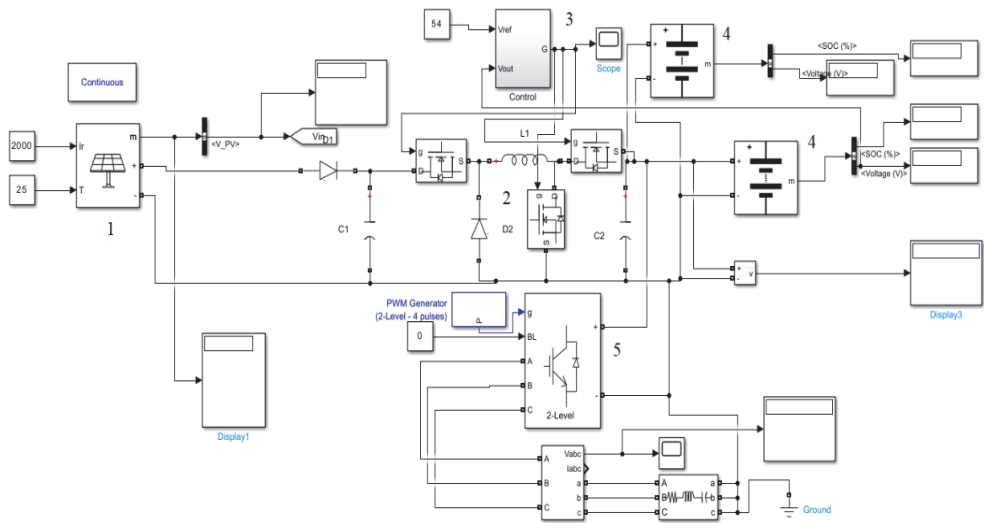

Figure 2. Model of a hybrid PV system

The function of the modelled solar system corresponds to the block diagram in fig. 1, where the model of the solar panels block – 1 is presented as a model of solar arrays where the number of solar panels in the arrays can be specified. The output of the block can also be designed according to the design whether a high voltage output is required (connection of the PVs in series) or high current output (PVs connected in parallel). Two input parameters – solar irradiation – I_r and the ambient temperature T are specified in the model as the solar arrays performance is strongly dependent by their values (low values of irradiation provides less output power and also temperatures different than 25 degrees Celsius degrade the optimal power output even with the highest sun). The power output of block 1 must be specified according to the input of the charge controller – 2, 3 and the inverter 5 and the battery storage – 4. The charge controller block is comprised of two sections – a step up buck converter – 2 and a voltage controller – 3. The step-up DC-DC buck converter is used to maintain constant voltage fed to the batteries, due to the changing PV power output during the day. The DC-DC converter is comprised of solid-state relays switching circuitry, a capacitor C and inductance L. The converter is used to boost the output power during the beginning and the end of the sun radiation. The switching circuitry is controlled by the voltage controller PWM output in order to provide constant output voltage to the batteries and cut off the power input in case the batteries – 4 are fully charged. A generic lithium-ion battery model used is the simulation, the model uses several parameters available for change – the ambient temperature effect, battery maximum voltage, state of charge and aging effect if required. In case the PVs are not producing power, the power inverter – 5 is switched to the battery storage. The inverter outputs three phase AC voltage. It is connected to a three phase load for measurement purposes for future experimental purposes as the battery pack is connected in parallel to the inverter input providing maximum magnitude of $\frac{1}{2}$ of the battery voltage..

Several monitoring oscilloscopes and displays are connected to measure and visualize, voltage, PWM and state of charge of the battery storage.

The configuration used for the purpose of the simulation experiment is as follow:

- Number of solar panels in series
- Number of solar panels in parallel
- Irradiation I_r – 2000 W/m²,
- Ambient temperature T – 25 C,
- Battery maximum voltage – 54 V,
- Current battery voltage – 36 V,
- Batteries state of charge – 20%
- Battery 1 capacity – 20 Ah
- Battery 2 capacity – 100 Ah,
- Operation time – 120 seconds

The experiment shows an increase in the battery charge of 30% for the battery with 20 Ah capacity and 23% for the battery with 100 Ah capacity. The difference of 7 volts respectively from their initial state. For illustrative purposes the measurement was performed without taking into consideration the impact of temperature and irradiation on the performance as their input is constant as can be seen in fig. 2. The results can be seen in fig. 3.

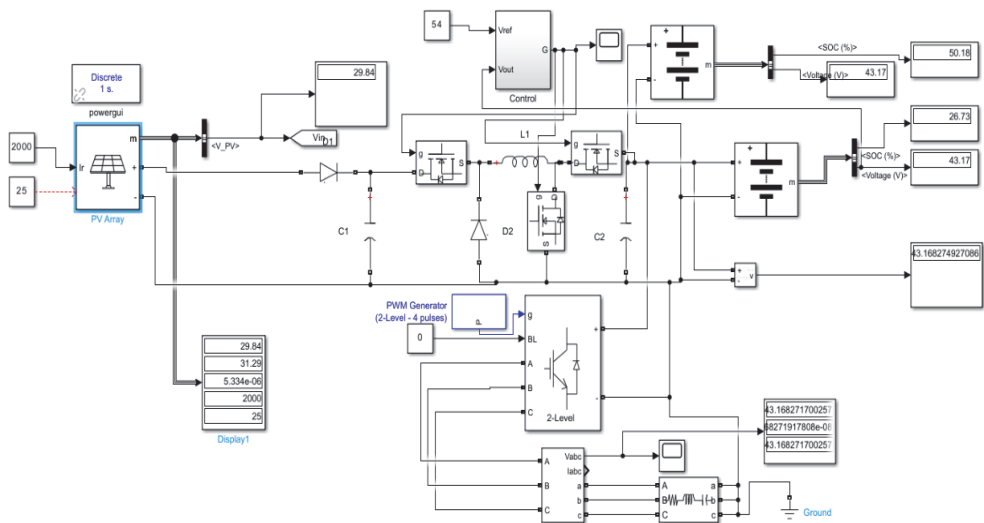

Figure 3. Experimental results of the PV system performance

In order to provide realistic results, it is necessary to input variable irradiation and temperature to the battery and solar packs. Such data can be obtained by the weather forecast datasets, which transferred to a string can be input into the model. Another direction is involvement of the aging effect of the battery storage.

The simulation presented in this work aims to provide directions for the design of a photovoltaic system. A real solar system contains greater number of solar panels and battery packs and also in contrast with the experiment, a power consumption affecting the performance is usually present in real systems.

CONCLUSION

The present article presents a design approach for a hybrid solar system. Taking into account the structure of such systems and their input parameters and variables it is possible to create a model of a full-scale solar farm and storage system that will allow precise calculation of the required average irradiation, type of solar panels as well as the parameters of the voltage converters, regulators and storage capacity. The simulation used random data and does not involve variable parameters from the real systems which can greatly affect the accuracy. A numerical experiment verifies the applicability of the model and provides ground for further analysis and customization.

REFERENCES

- [1] J. Smith, „Advances in solar energy technologies“, Renewable Energy Journal, vol. 45, no. 2, pp. 132-145, 2010. ISBN: 978-1-23456-789-0.
- [2] A. Johnson and M. Miller, „Global depletion of resources and the impact on energy demand“, Energy Policy Review, vol. 33, no. 4, pp. 209-215, 2015. ISBN: 978-1-56789-012-3.
- [3] L. Brown et al., „Automated systems for control acquisition and monitoring in solar power systems“, Journal of Automation and Control, vol. 54, no. 6, pp. 67-74, 2017. ISBN: 978-3-112-34567-8.
- [4] R. Green, „Performance of SCADA systems in renewable energy“, Solar Energy Technologies, vol. 60, no. 1, pp. 23-28, 2018. ISBN: 978-1-90123-456-7.
- [5] T. White and C. Black, „SCADA-based control systems in solar energy management“, Journal of Renewable Energy Engineering, vol. 29, no. 5, pp. 99-105, 2019. ISBN: 978-0-123-56789-0.
- [6] K. Harris and D. Wilson, „Improving the specific output power density of solar panels“, Energy Research Letters, vol. 22, no. 3, pp. 145-152, 2021. ISBN: 978-0-112-34567-9.
- [7] F. Taylor, „Optimization of solar panel performance across varying sunlight angles“, Solar Power Research, vol. 16, no. 2, pp. 56-63, 2019. ISBN: 978-1-567-89012-3.
- [8] M. Adams, „Load balancing in solar power systems to mitigate shadowing effects“, Renewable Energy Systems, vol. 47, no. 1, pp. 34-40, 2020. ISBN: 978-0-345-67890-1.
- [9] P. Scott, „Energy storage solutions for photovoltaic systems“, Journal of Energy Storage, vol. 11, no. 4, pp. 55-62, 2018. ISBN: 978-1-234-56789-1.
- [10] L. Roberts and S. Davis, „Hybrid photovoltaic systems and their efficiency“, Journal of Green Energy, vol. 28, no. 3, pp. 102-108, 2022. ISBN: 978-0-987-65432-1.
- [11] R. Clark, „Meteorological effects on solar power output“, Energy and Climate Change Journal, vol. 30, no. 6, pp. 213-220, 2017. ISBN: 978-1-234-56789-0.